

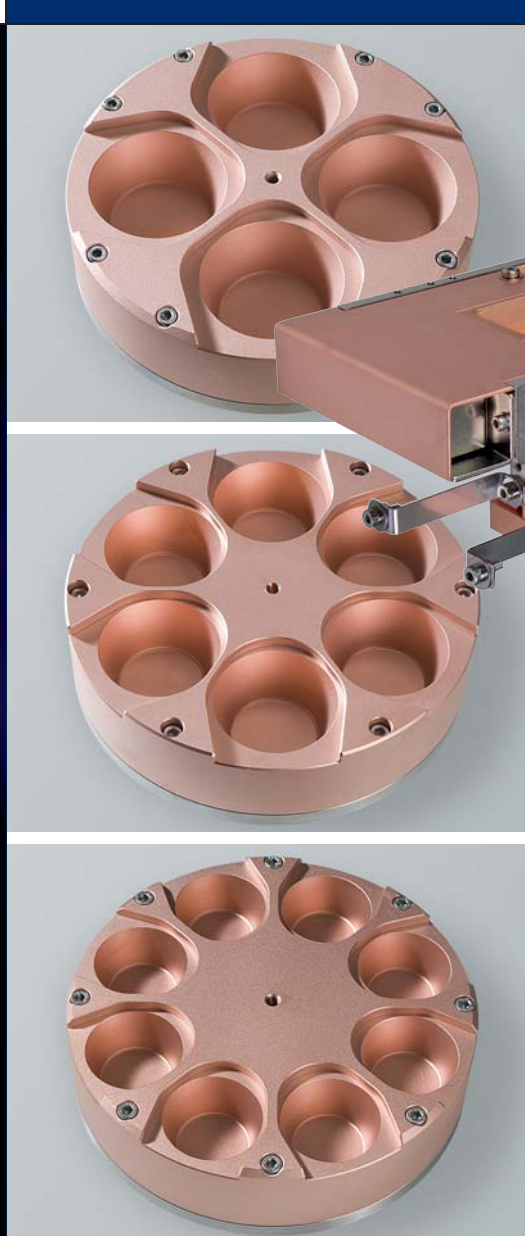

The EV M-6 multihearth electron beam evaporator is specifically designed for applications requiring high deposition rates and effective material utilization. Typical applications are production coatings or laboratory-scale evaporations with a variety of different materials or with materials that require continuous pocket rotation. The source offers unique technical features to enhance the reliability and repeatability needed in production environments.

Designed to be versatile

EV M-6 is used for optical, electronic and high rate deposition processes. Several standard crucible sizes are offered. If our standard crucibles do not fit your application requirements, FerroTec can design customized crucibles for you. This universal evaporator can be attached to most control systems and power supplies.



High capacity Multi-Hearth E-Beam Source EV M-6

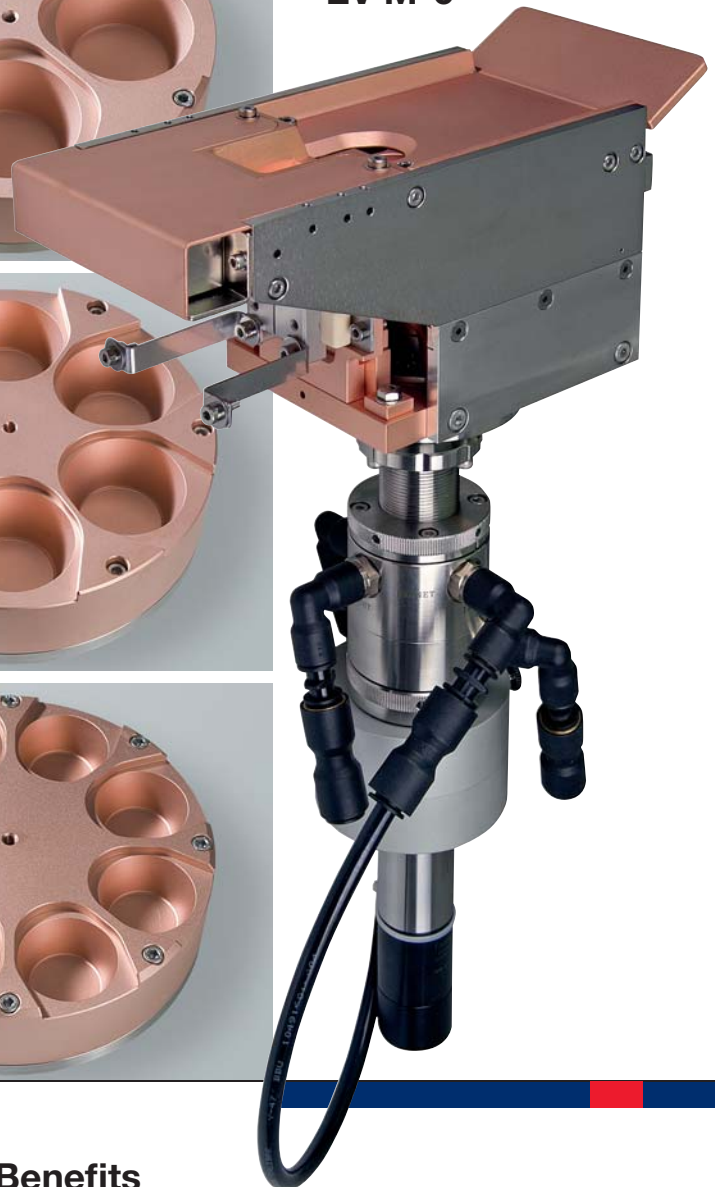

Advantages/Benefits

- Directly cooled crucibles with large capacity
- Homogeneous material depletion
- Stable beam sweep at high beam deflection frequencies
- Eliminates water leakage into vacuum system
- No additional water feedthrough required
- Reduced maintenance and down-time
- Enhanced run-to-run repeatability
- Built-in hearth rotation with high positioning accuracy
- Non-interchangeable connections

High capacity Multi-Hearth E-Beam Source EV M-6

Features

- Small beam spot regardless of position in pocket
- Low inductance x- and y-coils with dynamic defocusing capability
- No dynamic water-vacuum interface
- Integrated coaxial water feedthrough or hearth & source body cooling
- Long filament lifetime
- Reproducible & quick filament fixture
- Hearth positioning using optical encoder
- Plug-in connector for magnet leads

■ Technical Data EV M-6

Max. Power	6 kW
Acceleration Voltage	4–10 kV
Max. Filament Current	50 A @10 VAC
Primary Beam Deflection by permanent magnet	270 °
Bake Out Temperature	150 °C
X-Deflection	± 3 A (150 Hz)
Y-Deflection	± 3 A (150 Hz)
Spot Size Diameter < 3 mm with no or minimal variation between front- and back side of pocket	
Max. Evaporation Rate Depending on hearth configuration up to: Al > 12.000 Å/min @ 6 kW (250 mm source – substrate distance)	
Min. Base Pressure	10 ⁻³ mbar
Cooling Water Requirements	6 l/min
Mounting Requirements base plate hole	32 mm
Weight	12 kg (26,5 lb)
Part-No.	1-61 00 00

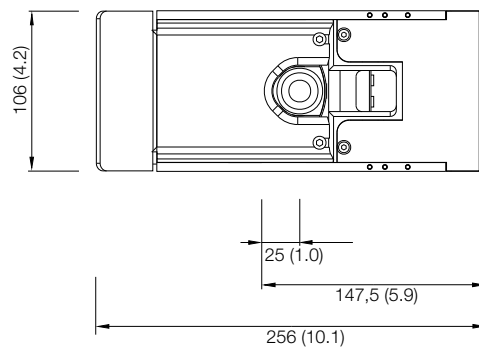
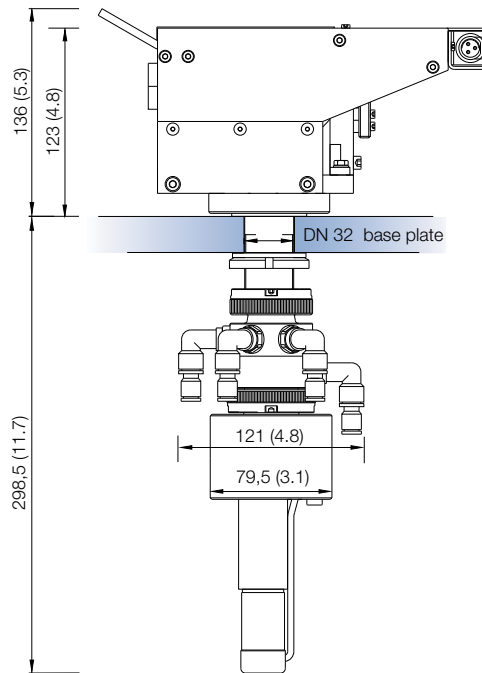

Dimensions in mm (inches)

Applications

Especially designed for optical and electronic applications the EV M-6 will be installed in large Systems to produce high quality filters and metal layers. Using crucibles for four/six/eight hearths the quantity is 8cc/4cc/2cc per hearth.

Simple to maintain

The EV M-6 has been designed for easy maintenance and service. Our newly designed crucible cover can be removed with only two screws allowing the crucible to be exchanged for cleaning or replacement in just a couple of minutes. Likewise, the cathode assembly is removed in seconds by removing only one screw. The filament may be exchanged in a few minutes outside the chamber. The new filament assembly tool allows precise alignment of the filament to the filament block. One Beam Emitter Assembly Set includes a retainer, screwdriver and tweezers.

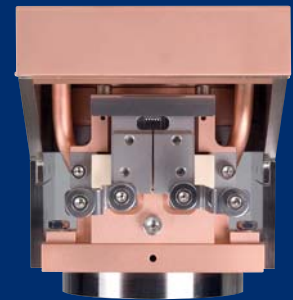

Ferrotec

USA

Ferrotec (USA) Corporation
33 Constitution Drive
Bedford, NH 03110, USA
Tel.: +1-603 472-6800
Fax: +1-603 472-2511
info@ferrotec.com
www.ferrotec.com

Germany

Ferrotec GmbH
Seerosenstraße 1
72669 Unterensingen
Tel.: +49-70 22-92 70-0
Fax: +49-70 22-92 70-13 99
gmbh@ferrotec.com
www.ferrotec.com

Japan

Ferrotec Corporation
1-4-14 Kyobashi
Chuo-ku, Tokyo 104-0031
Tel.: +81 3 3281 8808
Fax: +81 3 3281 8848
info@ferrotec.co.jp
www.ferrotec.co.jp

China

Hangzhou Dahe Thermo-
Magnetics Co., Ltd.
No.3 Nanxin Road, Zhejiang
Hi-tech Zone, Hangzhou,
Zhejiang, P.R. China
Tel.: +86 5 71-86 69 68 68
Fax: +86 5 71-86 69 70 99
ferrotec@ferrotec.com
www.ferrotec.com.cn